

COD.	DESCRIÇÃO	DIMENSÃO=MM	QTD.	VOL.	COD.	DESCRIÇÃO	DIMENSÃO=MM	QTD.	VOL.
9519	LATERAL DIREITA	445X1.990X12	01	1/2	9532	TRAVAMENTO DO RODAPÉ	112X414X15	01	1/2
9520	LATERAL ESQUERDA	445X1.990X12	01	1/2	9533	MOLDURA	70X1.653X15	01	2/2
9521	LATERAL INTERNA DIREITA	445X1.800X12	01	1/2	9534	MOLDURA FRONTAL	94X1.808X15	02	2/2
9522	LATERAL INTERNA ESQUERDA	445X1.800X12	01	1/2	9535	PORTA	445X1.808X15	02	2/2
9523	BASE SUPERIOR	445X1.629X12	01	1/2	9536	PORTA DE ESPELHO	315X1.080X15	01	2/2
9524	TAMPO INFERIOR	445X535X06	02	1/2	9537	FRENTE DE GAVETA	174X543X15	02	2/2
9525	TAMPO DO GAVETEIRO	445X535X12	01	1/2	9538	FRENTE DE GAVETA COM CHAVE	174X543X15	01	2/2
9526	TAMPO MENOR	355X535X12	01	1/2	9539	LATERAL DIREITA DE GAVETA	130X350X12	03	2/2
9527	PRATELEIRA	355X535X12	03	1/2	9540	LATERAL ESQUERDA DE GAVETA	130X350X12	03	2/2
9528	PRATELEIRA MENOR	230X535X12	01	2/2	9541	CONTRA FUNDO	115X486X12	03	2/2
9529	PRATELEIRA INTERNA	200X535X12	02	2/2	9542	FUNDO DE GAVETA	350X496X03	03	2/2
9530	RODAPÉ	112X1.629X15	01	2/2	9543	FUNDO TRASEIRO	546X1.830X03	02	2/2
9531	RODAPÉ TRASEIRO	112X1.629X15	01	2/2	9544	FUNDO TRASEIRO CENTRAL	546X1.830X03	01	2/2



accessories accesorios accessoires acessórios

A066 (X48)		A062 (X36)		A054 (X108)		A193 (X18)	
A567 (X04)		A114 (X40)		A082 (X04)		A121 (X10)	
A092 (X01)		A073 (X16)		A129 (X90)		A118 (X20)	
A092 (X08)		A371 (X06)		A615 (X01)		A616 (X01)	
A617 (X02)		A382 (X01)		A365 (X03)		A506 (X05)	
A628 (X06)		A658 (X02)		A122 (X15)		A372 (X02)	

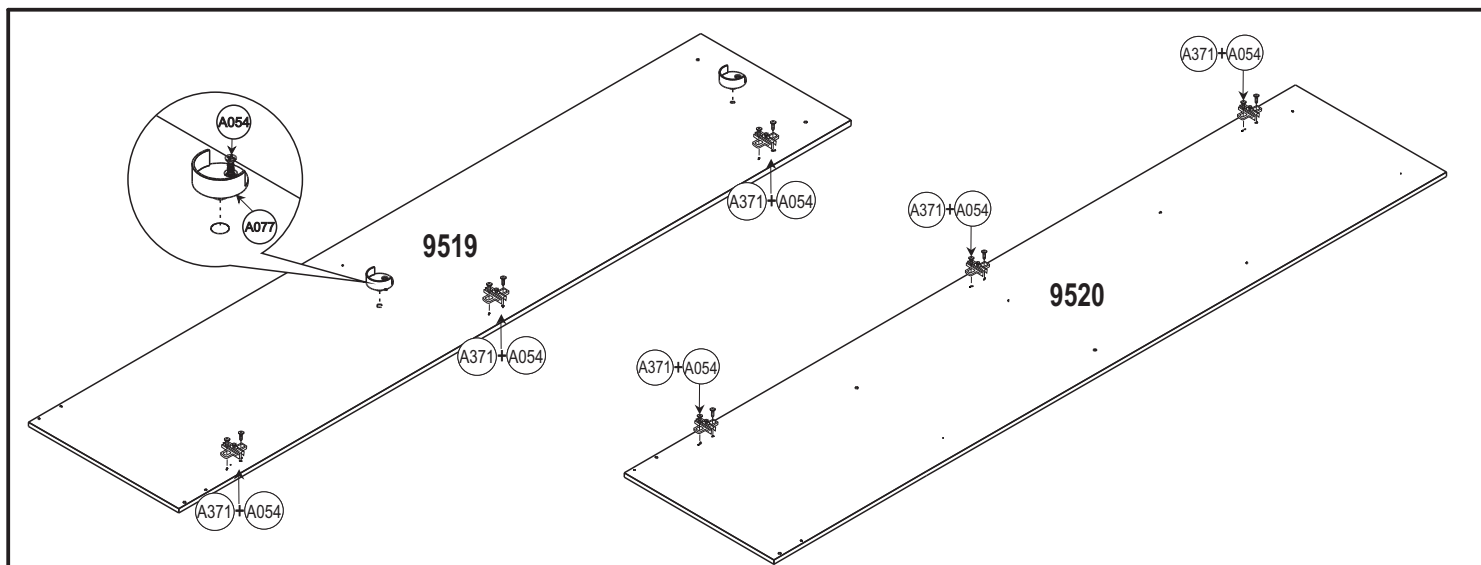

**ESCANEE O QR CODE
E CONHEÇA NOSSA
LINHA DE PRODUTOS.**



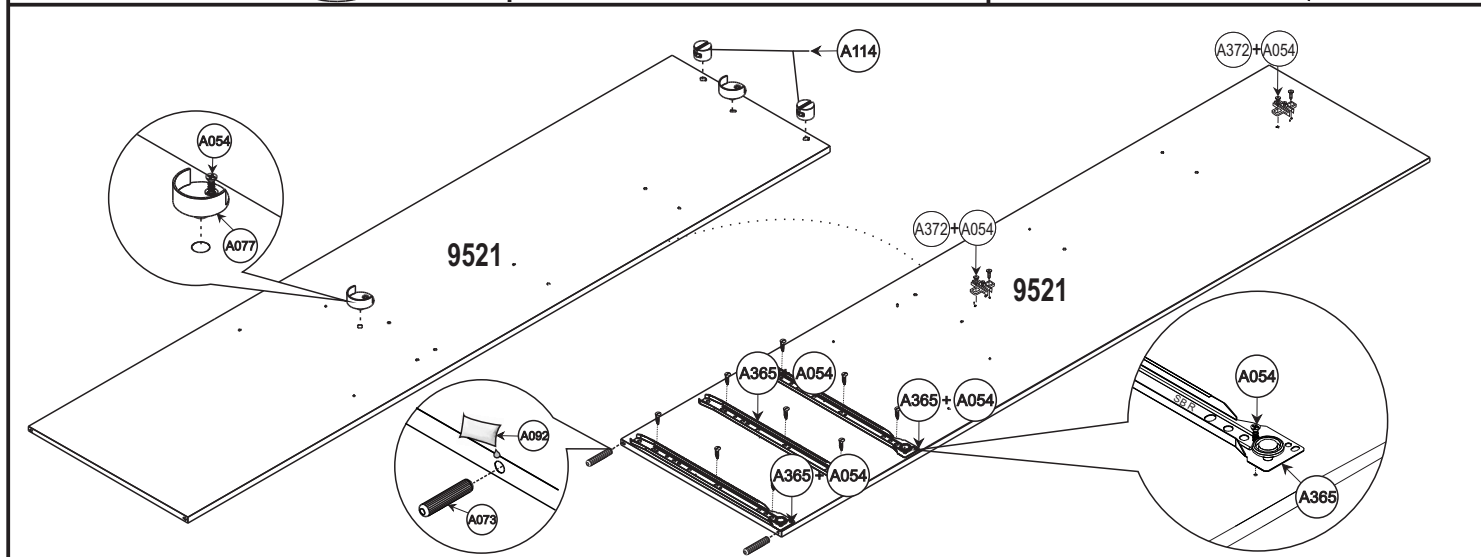

<p>A077</p> 	<p>A054</p>  <p>(3,5X12 CC)</p>	<p>A371</p> 
---	--	---

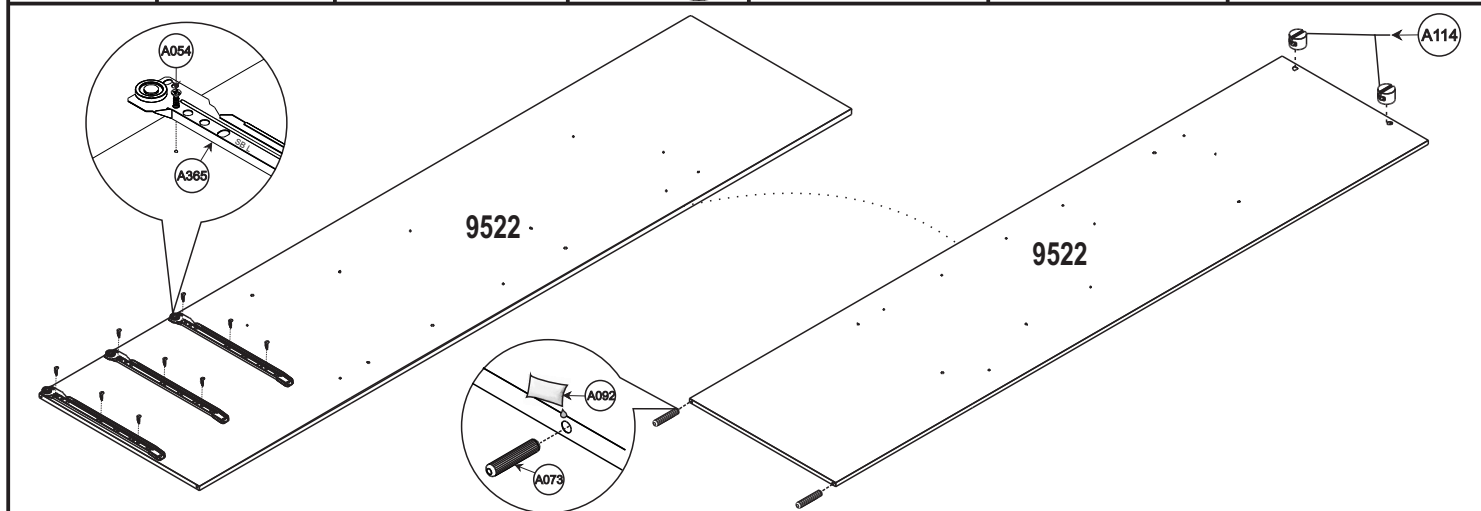

<p>A077</p> 	<p>A054</p>  <p>(3,5X12 CC)</p>	<p>A372</p> 	<p>A114</p> 	<p>A092</p> 	<p>A073</p>  <p>(6X30 MM)</p>	<p>A365</p>  <p>(350 MM)</p>
---	--	---	---	--	--	---

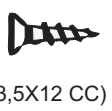

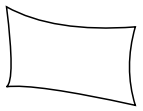
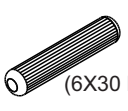
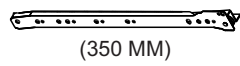

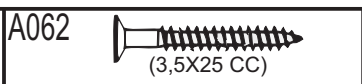
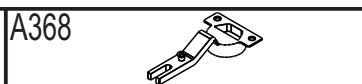
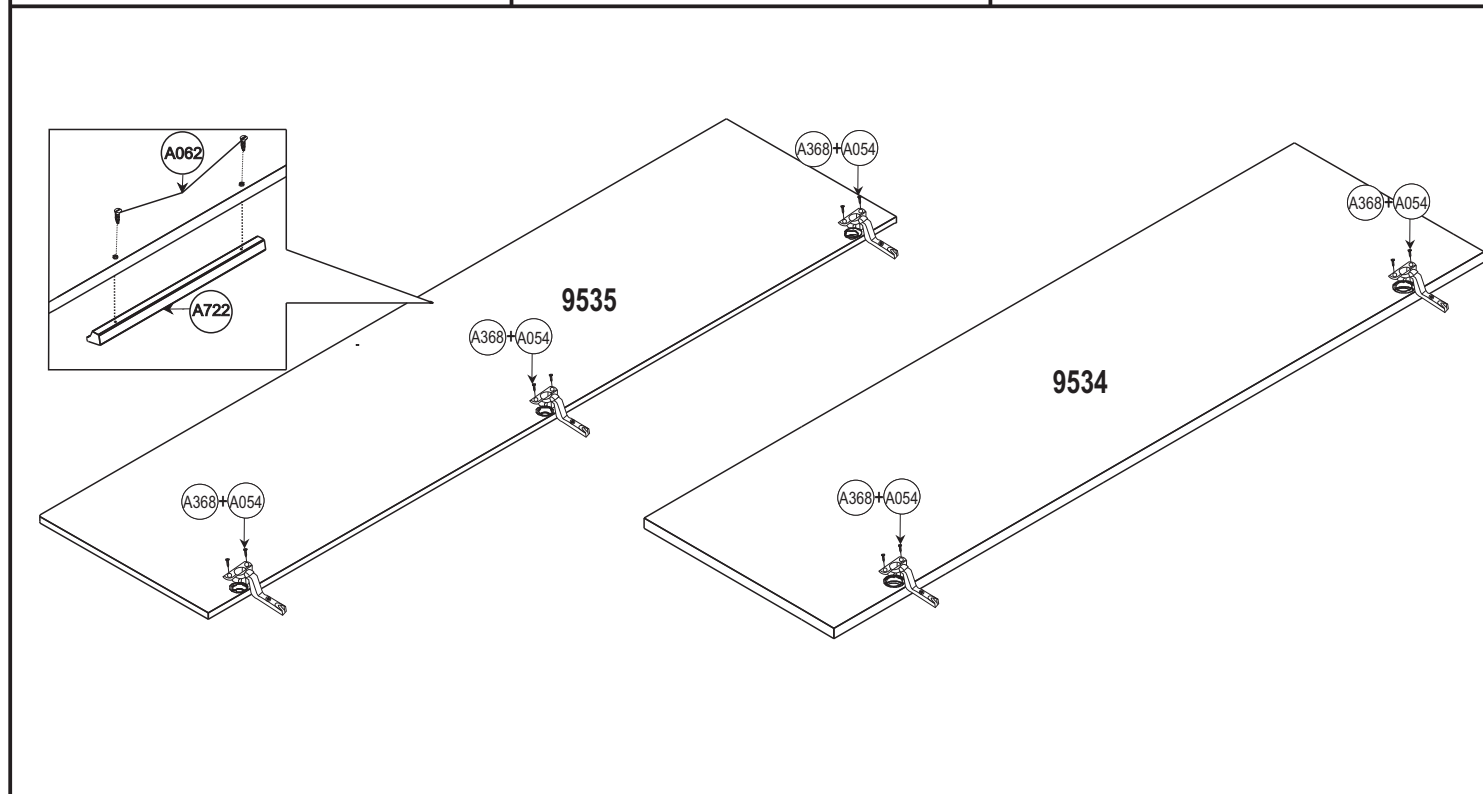
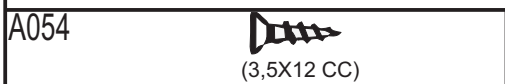
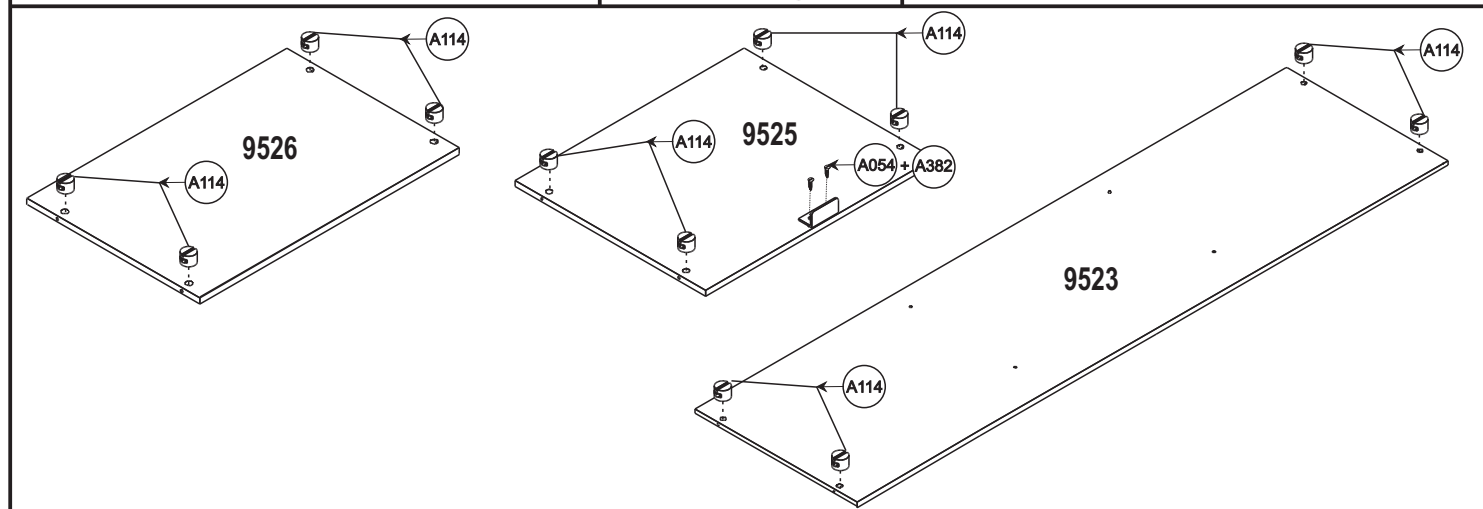
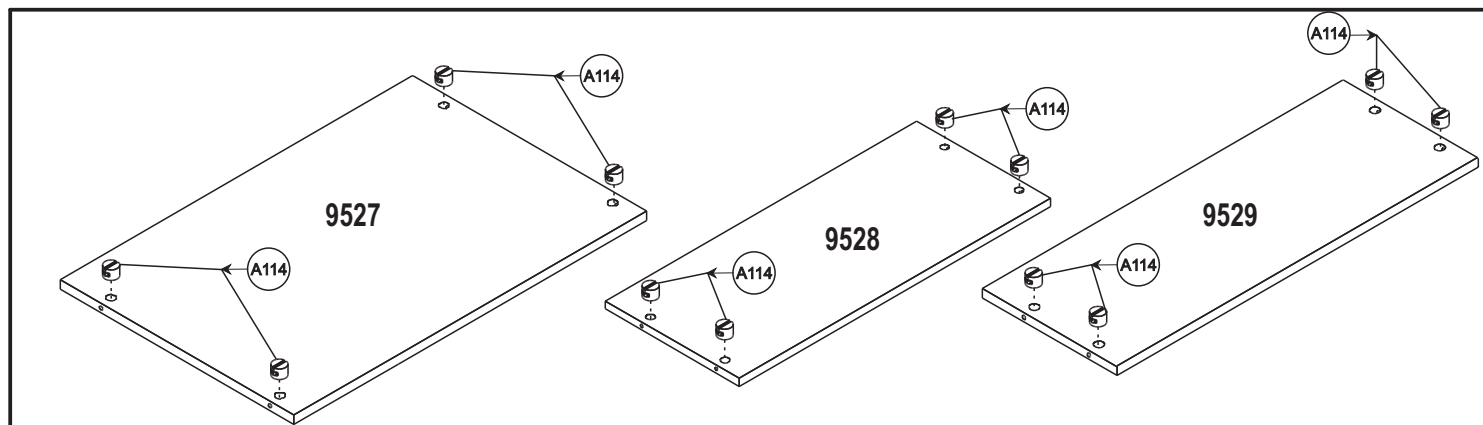

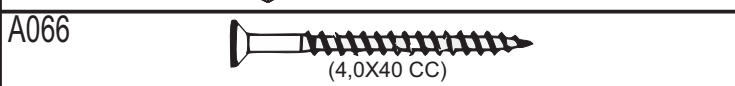
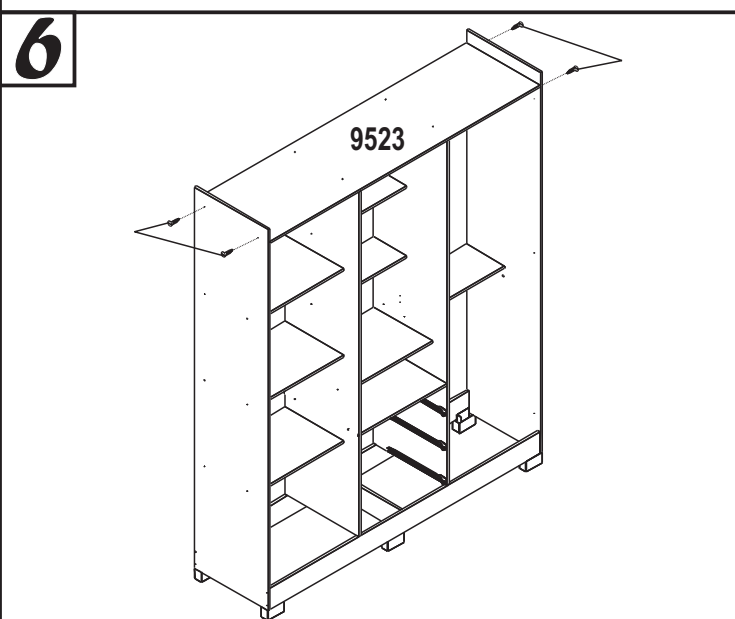
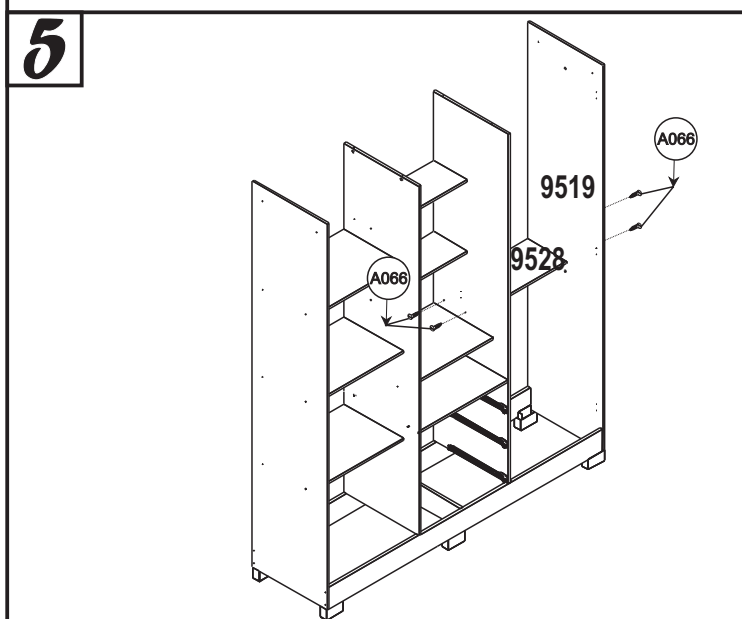
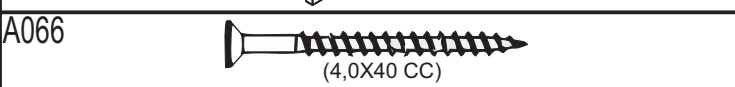
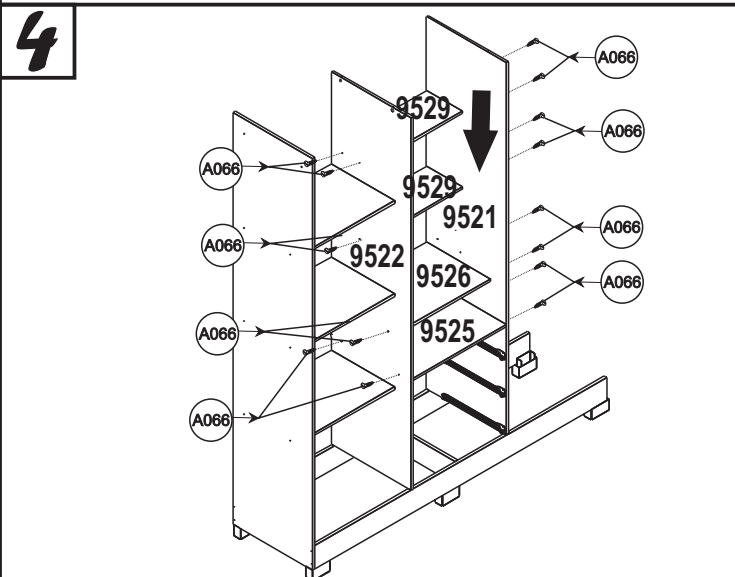
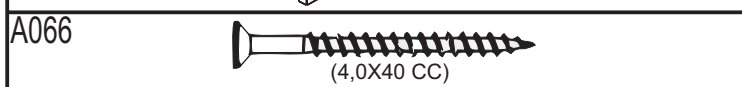
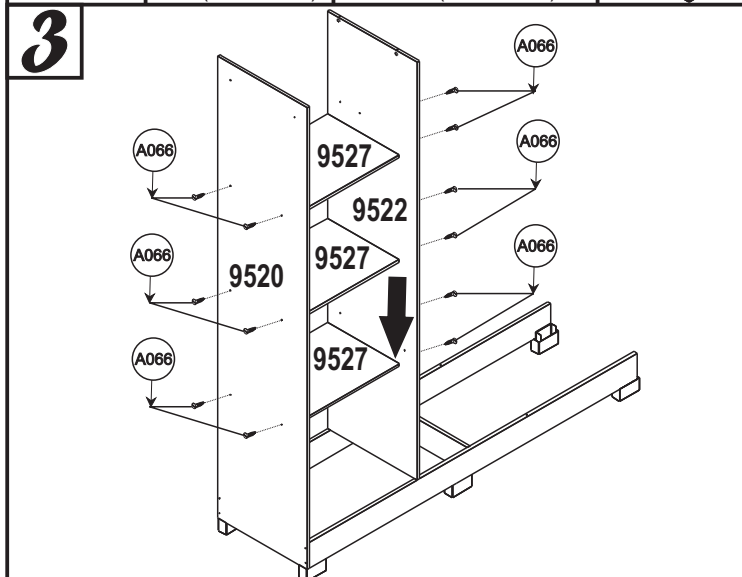
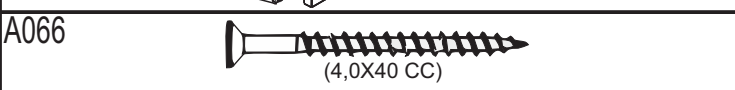
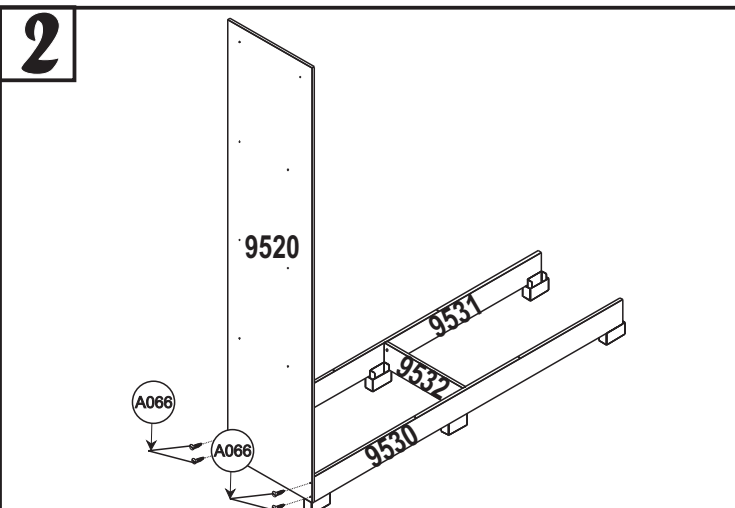
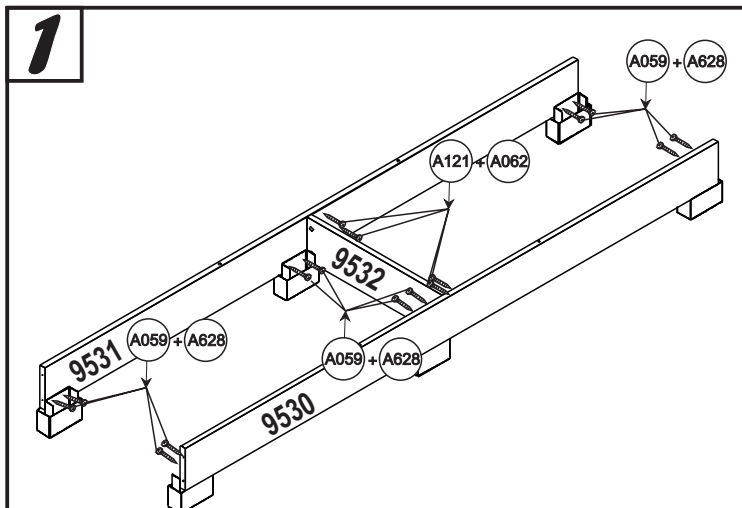

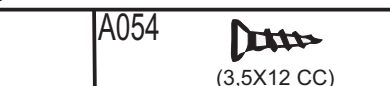
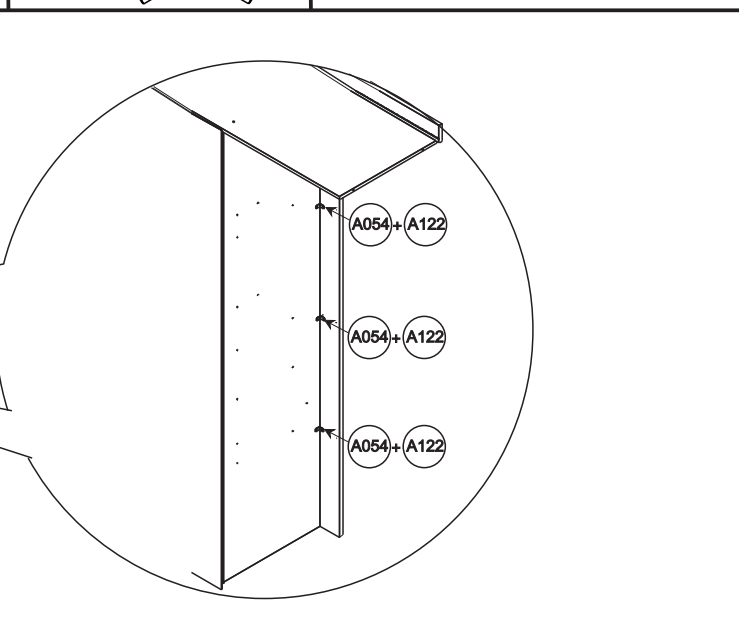
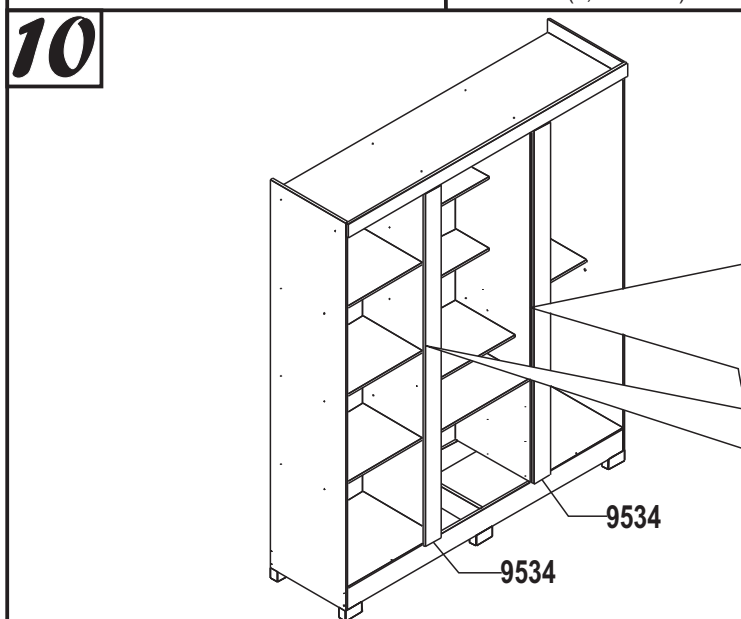
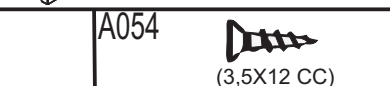
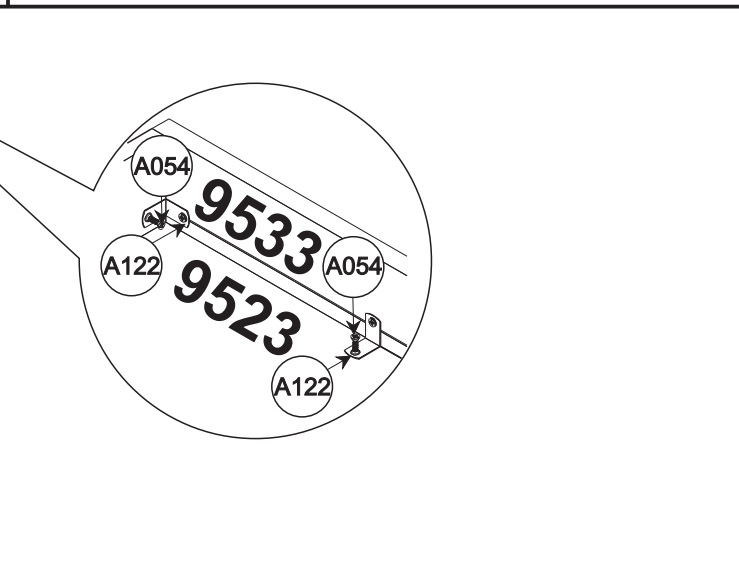
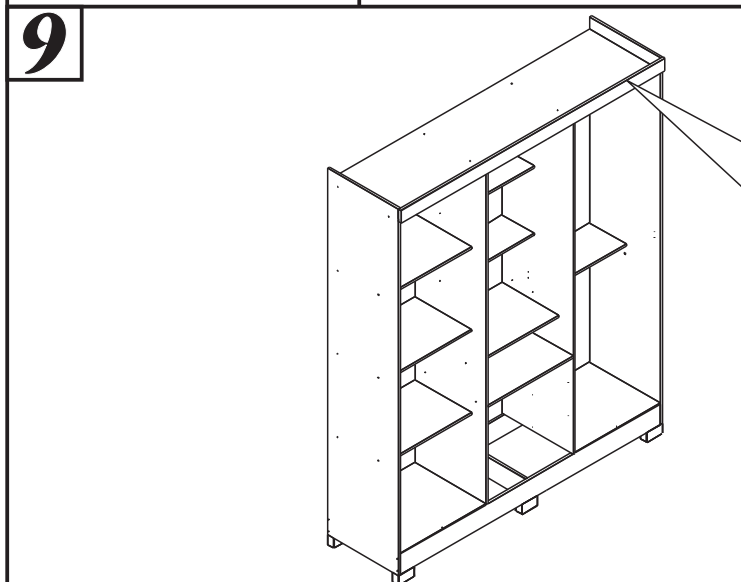
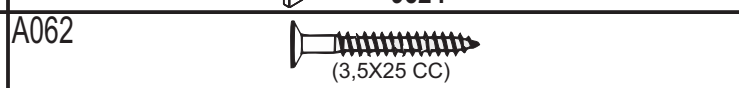
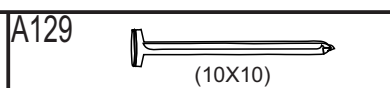
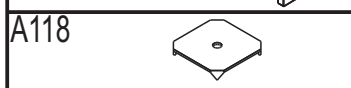
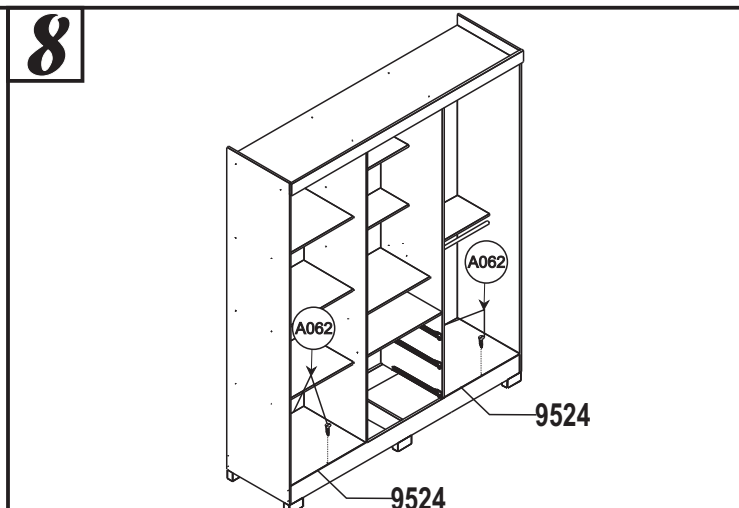
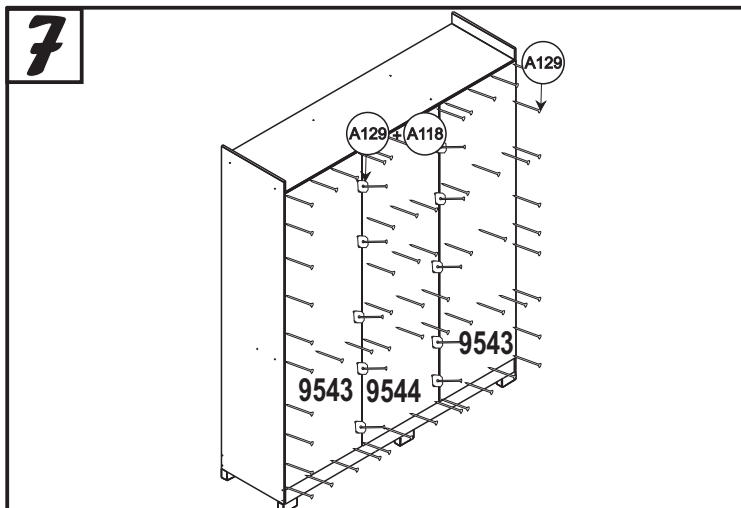

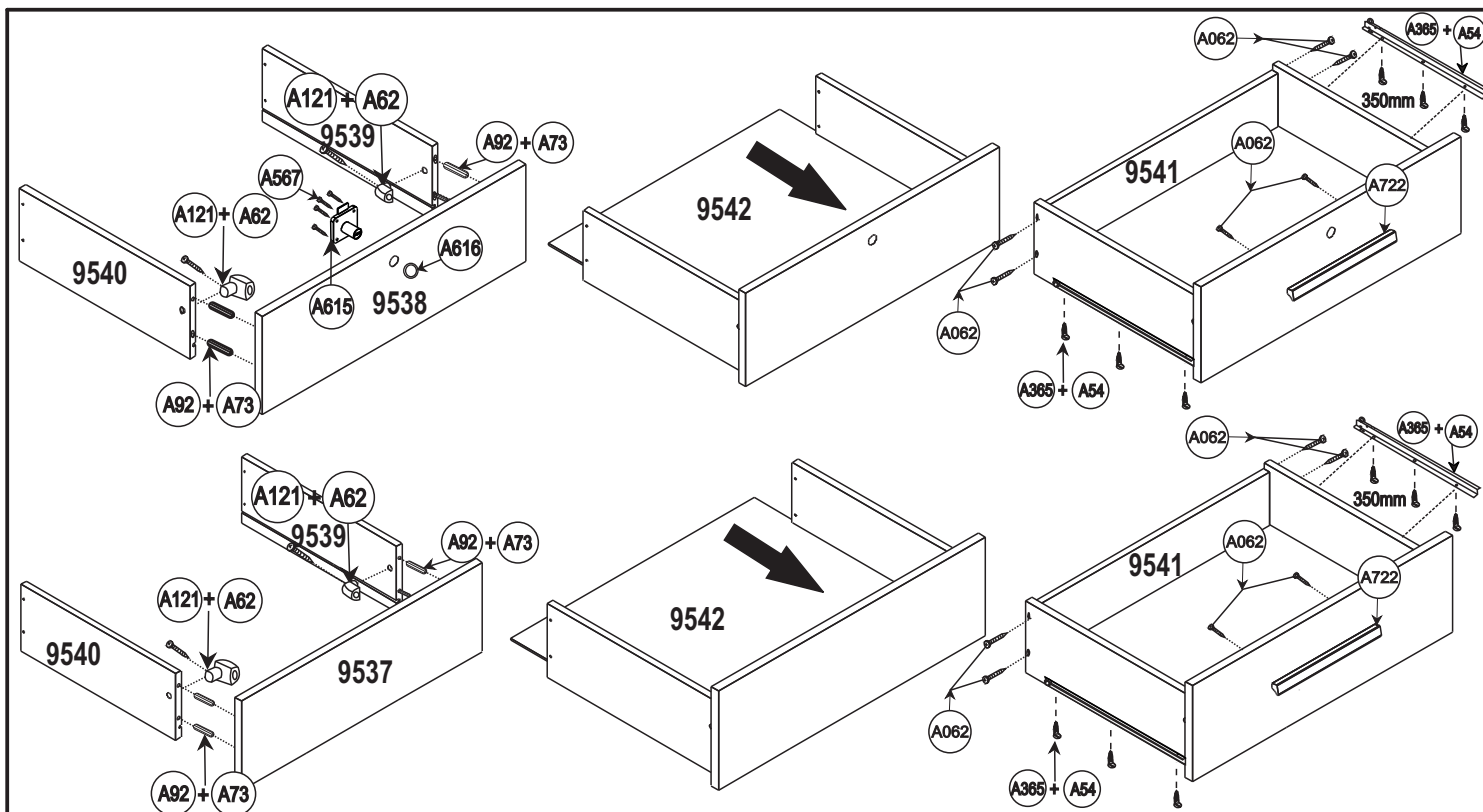
<p>A054</p>  <p>(3,5X12 CC)</p>	<p>A114</p> 	<p>A092</p> 	<p>A073</p>  <p>(6X30 MM)</p>	<p>A365</p>  <p>(350 MM)</p>
--	---	---	--	---





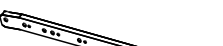



A567  (4,0X16 CC)	A062  (3,5X25 CC)	A073  (6X30 MM)	A365  (350 MM)
A615 	A616 	A722 	A092 

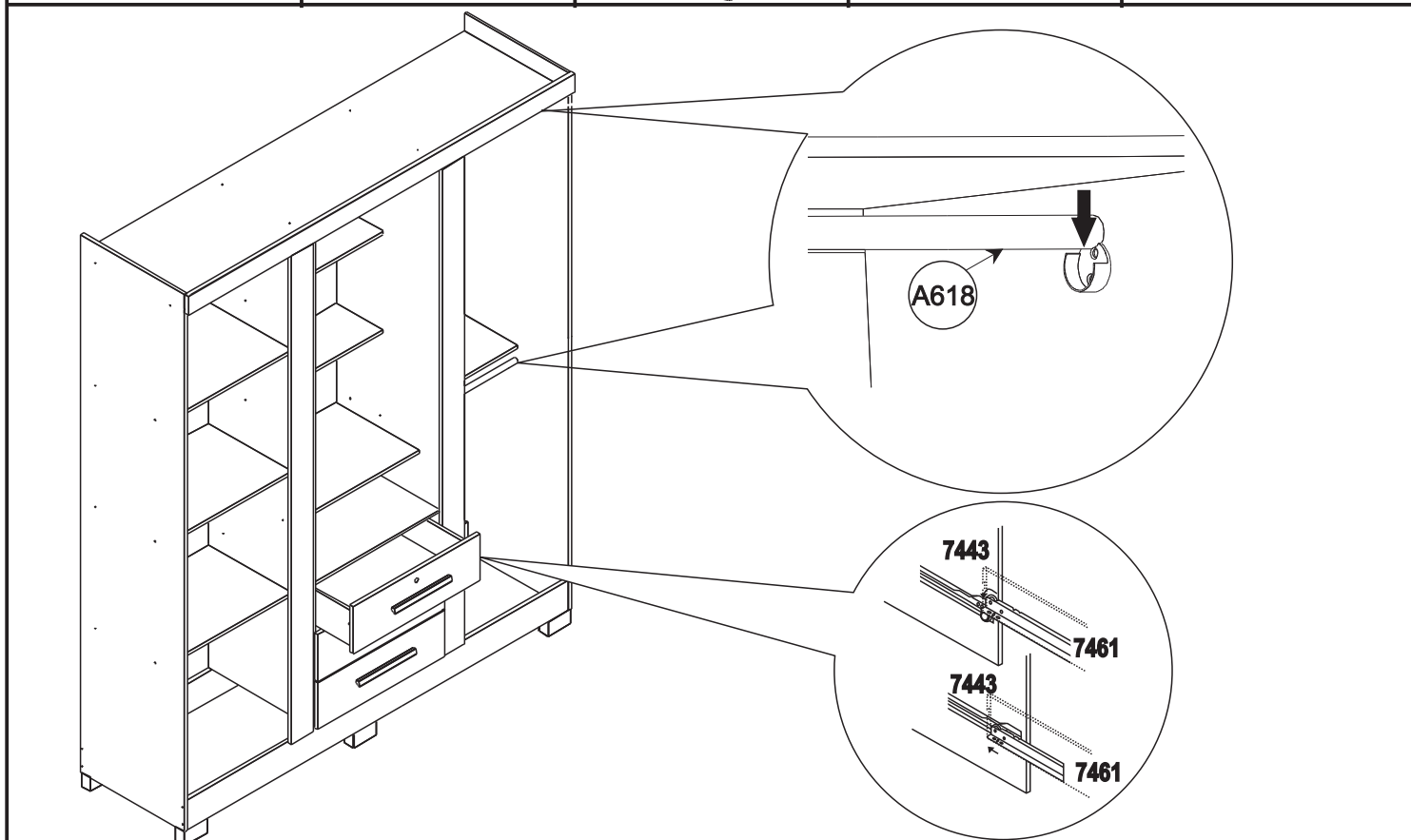

A658 	
--	--

09

FIXAÇÃO DO ESPELHO
 FIJACIÓN DEL ESPEJO
 INSTALLING MIRROR
 FIXATION DU MIROIR

ATENÇÃO!
 FIXAR O SUPORTE BEM NO CENTRO DO FURO,
 PARA EVITAR A QUEBRA DO ESPELHO.
 NÃO UTILIZAR A MAQUINA PARA A
 FIXAÇÃO DO ESPELHO.

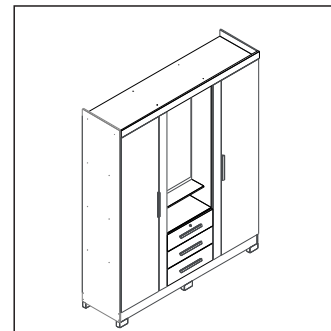
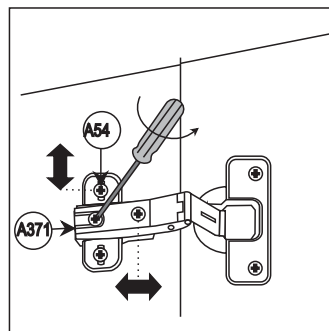
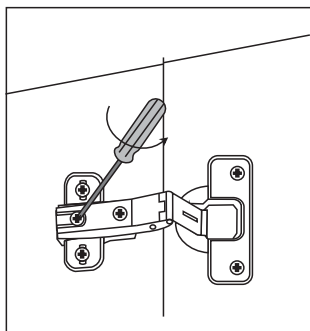
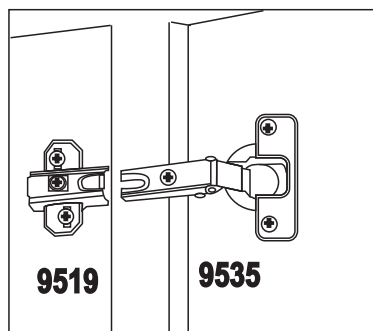
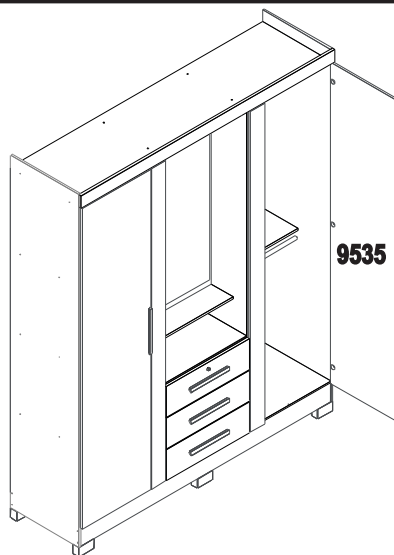
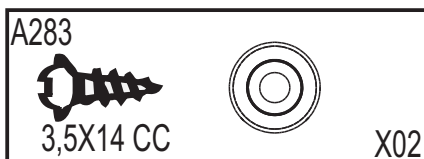
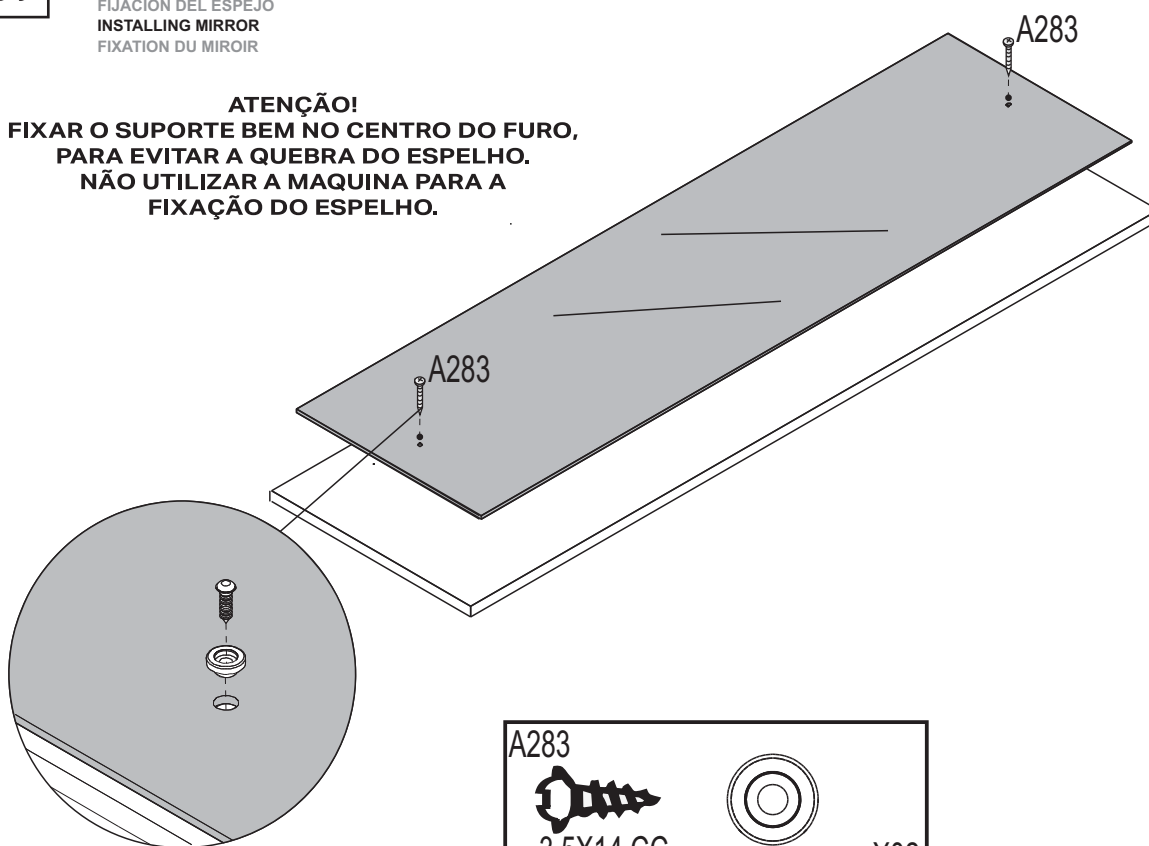

- In order to adjust correctly the door, please observe the picture. In order that the doors stay at the same level the adjustment should be done through the screw A374 from A371 accessory.
- Para ajustar correctamente la puerta, por favor observe la imagen. Para la permanencia de puertas en el mismo nivel el ajuste debería ser hecho por el tornillo A374 del accesorio de A371.
- Pour ajuster correctement la porte, observez s'il vous plaît l'image. Afin que les portes soit au même niveau l'ajustement devrait être fait par la vis A374 de l'accessoire A371.
- Para o ajuste ideal das portas, observe a foto em destaque. Para que as portas fiquem no mesmo nível, o ajuste deverá ser feito através do parafuso A374 do acessório A371.